

ADDENDUM #001
Orcutt Union School District
Technology Building Renovation
Bid # 10-2021-08-17-01

1. **Bid day and time remain as originally advertised: Wednesday, September 8th 2021 @ 2:00 p.m.**
 - a. Email bids to dnichols@telacu.com

2. **Specified Finishes:**

- a. **Paint:** Dunn Edwards – Color TBD - Eggshell (or approved equal)
- b. **Tack-Board:** Chatfield-Clarke Company, Inc. – Misty-Grey (or approved equal)
- c. **Carpet:** Bentley 40028 Shapeshifter Subatomic (or approved equal)
- d. **Resilient Wall Base:** Armstrong R48MG Metal Gray (or approved equal)

3. **Added Item** - Remove and replace **all** interior doors and frames with new (include new hardware). Bid added door scope per the respective base bid and alternate bid areas.

- a. New Door Frames are to be hollow frame.
- b. New doors are to be 3'x7' solid wood doors
- c. New Office & kitchen doors are to include vision lite at top half of door per detail provided herein.
- d. Restroom Door is to be solid wood, no vision lite.
- e. Paint Interior doors and door frames, color TBD.
- f. All Doors are to be lockable, except for new kitchen door.
- g. Refer to Addendum #1 Bid Drawing 1.0 for additional details.

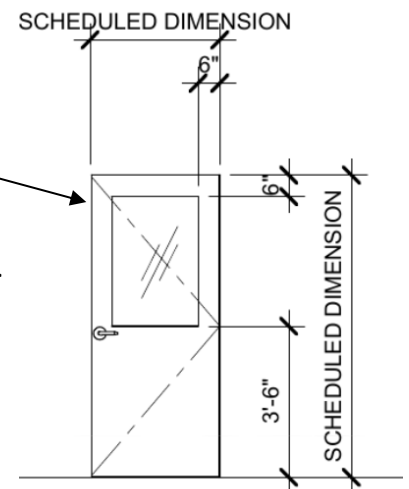

4. **Electrical Contractor Selection**

- a. Provide name and information of selected electrical contractor in the designated "Subcontractors" section of the bid form (section 3 of bid form).

5. **Pre-Bid RFIs:** See attached Responses

- a. Pre-Bid RFI #1: See attached RFI.

6. **Job Walk Sign-In Sheet**

- a. Mandatory Job Walk Agenda and Sign-in sheet are attached.

Project Contact:

David Nichols
Project Engineer
TELACU Construction Management
714-336-0899
dnichols@telacu.com

OUSD Technology Building Renovation (Bldg. 100)

Notes:

- Dimensions shown are not exact. Verify Dimensions In Field.
- Approved Submittals and/or samples required for all finish products.

Specified Finishes:

Paint:

Dunn Edwards – Color TBD - Eggshell (or approved equal)

Tack-Board:

Chatfield-Clarke Company, Inc. – Misty-Grey (or approved equal)

Carpet:

Bentley 40028 Shapeshifter Subatomic (or approved equal)

Resilient Wall Base:

Armstrong R48MG Metal Gray (or approved equal)

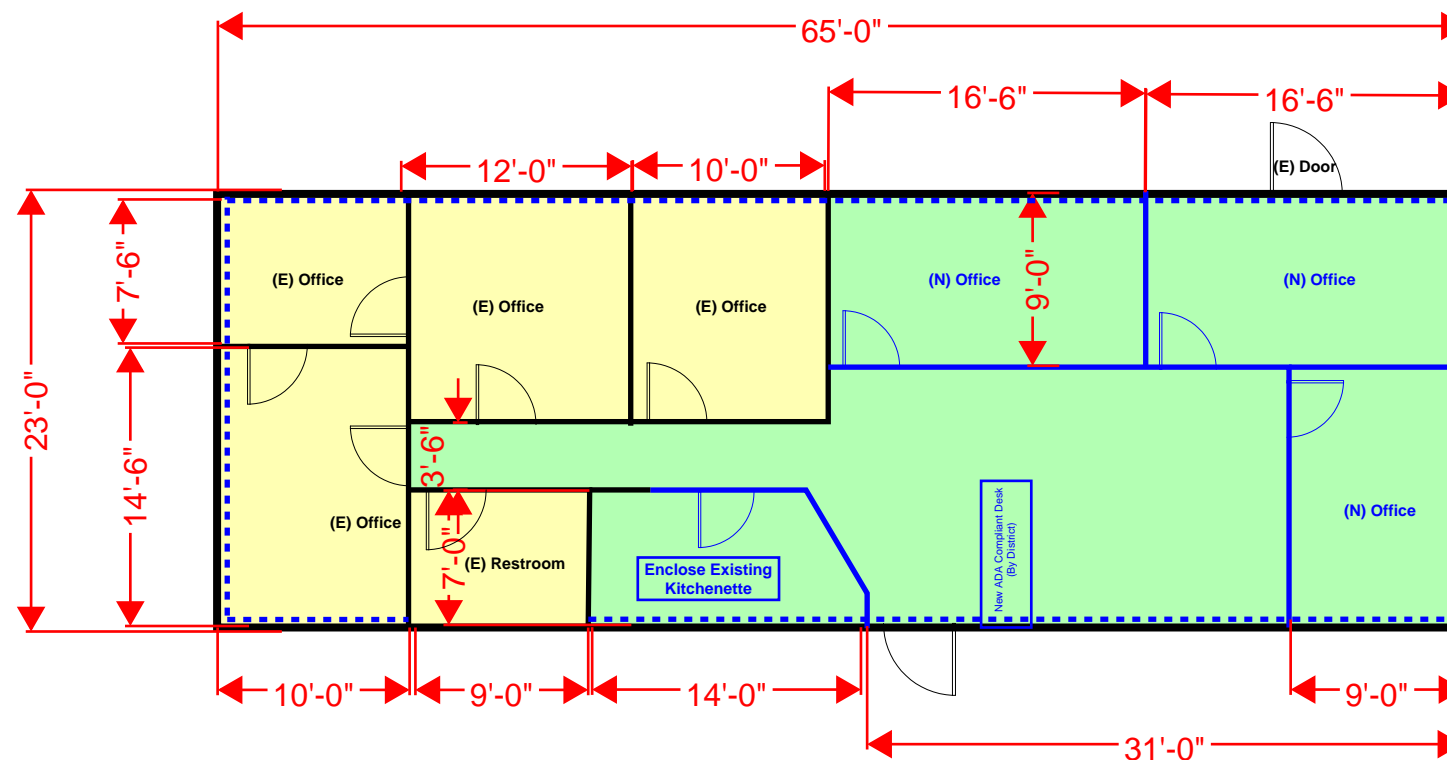

LEGEND

Base Bid Work Area



Alt Add Work Area

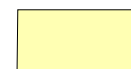

New 2x4 Walls



Existing Walls

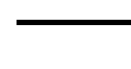

New Tack-Board (Full Height)



ADD ALTERNATE SCOPE BID NOTES:

- Alternate Bid Work Area is approx. 550 Square Feet.
- Furnish & Install new flooring and resilient base
- Furnish & Install new tack board at interior side of ext. walls
- Patch/Repair drywall walls (walls w/o tack board) and provide new paint
- Patch/Repair existing ceilings at offices (Owner Allowance).
- Clean-up existing electrical, provide wire mold as needed (Owner Allowance).
- **ADDENDUM-1 Remove & replace (6) interior 3'x7' doors and frames with new. New doors are to be solid wood, hollow metal frame & lockable door hardware. Include Vision Lite Kit for top half of door at (5) of the doors, no vision lite kit at restroom door. Refer to addendum #1 cover sheet.**

BASE BID SCOPE NOTES:

- Base Bid Work Area is approx. 900 Square Feet.
- Demo existing flooring
- Demo existing kitchen island, kitchenette to remain
- Demo Existing Casework at new office location.
- Frame new walls (2x4, drywall, painted)
- **ADDENDUM-1 Furnish & Install (4) new 3'x7' doors and frames. Doors are to be solid wood. Include hollow metal frame, door hardware & Vision Lite Kit for top half of door (refer to addendum #1). Include lockable door hardware at (3) doors, kitchen door will not be lockable.**
- Furnish & Install new flooring and resilient base
- Furnish & Install new tack board at interior side of ext. walls
- Replace all (10) windows at exterior walls. Use Operable Milguard Standard Aluminum or Approved Equal
- Patch/Repair existing ceilings at main room and new offices (Owner Allowance).
- New Data & Electrical Outlets - Locations TBD (Owner Allowance)
- Clean-up existing electrical, provide wire mold as needed. (Owner Allowance)
- Floor Outlets are to remain. Protect in place.

Rdz Contractors

Lic #1004110

(805) 458-5252

rdzcontractors@gmail.com

Request For Information

R.F.I. NUMBER: 001

To: David Nichols, Telacu

Project: OUSD Tech Bldg Renovation

R.F.I. DATE	REQUISITIONER	RESPONSE REQUESTED BY:	COST IMPACT	SCHEDULE IMPACT
9/1/2021			TBD	TBD

Drawing Ref.

Direction Not Given In Contract Documents.

Spec. Ref.

Interpretation Of Contract Documents.

Conflict In Contract Requirements.

Clarification Needed.

DESCRIPTION

- 1) Please verify (3) of the (4) new doors will be constructed with half glass?
- 2) Please verify (6) doors in alternate work will be constructed with half glass?
- 3) Please verify all new framing may be constructed with metal studs vs. wood?

Submitted By: Pete Rodriguez

REPLY

- 1) See Addendum #1 for added door details and requirements.
- 2) See Addendum #1 for added door details and requirements.
- 3) Wood and metal stud framing are acceptable for this project.

Response By: David Nichols TELACU CM Date: 9/3/2021

P.O. BOX 760 Nipomo, CA 93444
Tel. (805) 458-5252 Fax. (805) 335-6858

**Mandatory Job Walk Agenda
Orcutt Union School District
Technology Building Renovation
Bid # 10-2021-08-17-01**

Job Walk Date: August 31st 2021– 2:00 PM
Job Walk Location: Orcutt Union School District Office
500 Dyer Street, Orcutt, CA. 93455

Owner: Orcutt Union School District
Construction Manager: TELACU Construction Management

General Project Information:

Job Walk Sign In: All interested contractors are to sign in and provide contact information on the job walk sign in sheet. Please provide business cards to District Representative. The bid documents and communications for these projects will be sent to the individual listed as the contact as provided at this job walk and posted to the District website. In order to be deemed responsive, bidders must have attended and signed in to the job walk.

Bid Milestones and Schedule: August 31, 2021: Mandatory Job Walk
September 2, 2021: Last Day for Pre-Bid RFI's
September 3, 2021: Last Addendum Issued
September 8, 2021: Bids Due 2:00PM
October 13, 2021: Contract Award

Bid Documents: Project Documents are available on the District's web site.

Project Bid Documents consist of

01 - Bid Project Manual (CUPCCAA)

02 – OUSD Technology. Bldg. Renovation Bid Plan 1.0

Project Contact:

David Nichols
TELACU Construction Management
714-336-0899
dnichols@telacu.com

Brad Gitchell
Orcutt Union School District
805-938-8971
bgitchell@orcutt-schools.net

Construction Information:

Bidding Requirements: Class-B General Construction Contractor

Project's Preliminary Cost Estimate: The site construction cost is anticipated at less than \$200,000.

Project Duration: October 18, 2021 – November 19, 2021

Liquidated Damages: \$500 Per Calendar Day

Prevailing Wage: This project will use the Prevailing Wage rates with Certified Payroll Submitted to DIR and copied to TELACU Construction Management.

Contractor Work Hours: All construction and delivery activities shall be restricted to the hours of 7:00 a.m. to 6:00 p.m. Monday through Friday and from 8:00 a.m. to 5:00 p.m. on Saturdays, or as otherwise modified or amended. Sunday and/or Federal Holidays by request.

Staging: Contractor must coordinate with TELACU Construction Management for staging of materials and deliveries.

Pre-Bid RFIs: Email RFI's to dnichols@telacu.com no later than **3:30pm on Thursday, September 2nd, 2021**. Include your Company letterhead and contact information. If RFI is deemed to be valid, a formal response shall be issued as an addendum to all bidding contractors. Final Addendum will be issued on or before **Friday, September 3rd, 2021**.

Bid Alternate:

1. Additive Alternate #1: Alternate Add Scope Area (Yellow area on plan)
2. Additive Alternate #2: \$25,000 Owner's Allowance

Documents to Be Submitted with Bid: See page 1 of the Instructions to Bidders.

1. Bid Form
2. Bid Bond or other Security
3. Non-Collusion Declaration

Anticipated Addendum Items:

1. RFI Responses to RFI's received on or before September 2nd, 2021.

Site General Comments: No smoking or substance use, professional construction attire, no interaction with staff & students. All correspondence and communication to be directed to TELACU Construction Management. Bidders shall not contact the District directly for information related to the project.

General Scope of Work:

1. Demo existing finishes and casework as indicated on plan. Include removal of existing flooring and base if scope calls for new flooring at specified area(s).
2. Frame new walls, finish with painted drywall or tack-board as indicated on plan.
3. Patch and Paint Drywall, paint existing drywall to match new drywall (All areas, split work per base bid and alternate #1 bid areas).
4. Install new tack-board as indicated on plan.
5. Remove existing windows and replace with new windows.

Specified Finishes:

1. Paint: Dunn Edwards: Color TBD – Eggshell. 1 coat of primer, 2 coats of paint.
2. Tack-Board: Chatfield-Clarke Company, Inc. – Misty-Grey (or approved equal)
3. Carpet: Bentley 40028 Shapeshifter Subatomic (or approved equal)
4. Resilient Wall Base: Armstrong R48MG Metal Gray (or approved equal)

Additional Notes:

1. Basis of bid award will be the combined amounts of the base bid and Alternates #1 & #2.
2. Items to be covered under the Add Alternate #2 owners' allowance, if elected to be used (but not limited to). Items will be confirmed when contract work commences:
 - **Electrical** (T&M Basis)
 - Clean up existing electrical as needed
 - Add/relocate electrical and data outlets as needed
 - Remove unused electrical outlets in back offices
 - **Ceiling Repairs** (T&M Basis)
 - Patch & Touch Up Existing Ceiling
 - **Kitchen Casework**
 - Replace upper kitchenette casework



Mandatory Job Walk - Sign-In Sheet

Construction Management

Project: Technology Building Renovation

Date: 8/31/2021

District: Orcutt Union School District

Time: 2:00 PM

Locations: District Office Site

	PRINT NAME	ORGANIZATION	LICENSE CLASSIFICATION	PHONE	Email Address
1	Mark Schwid	Mark Schwid Elect		805-9294702	MSchwidElectric@bcastel.net
2	Chad McGray	Santa Maria Elec	B, C-10	805-922-7777	Andrew@smelectric.net
3	Pete Rodriguez	Rdz Contractors	A, B	805-458-5252	rdzcontractors@gmail.com
4	MIKE QUARESMA	FLOOR CONNECTION	C-15	805-481-2761	MQUARESMA@FLOORCONNECTION.COM
5	JESSICA VAZQUEZ	QUINCON, Inc.	A, B	805-574-1122	jose@quinconinc.com
6	LENNY SCHEINER	SMITH MEP	AB C10	805-621-5000	LSCHNEINER@SMITHMEP.COM Keloud@SMITHMEP.COM
7	JUSTIN KOERBER	R.F. KOERBER		805-400-5776	JUSTIN@RFKOERBER.COM
8	David Nichols				
9	David Nichols	TELACU CM	CM	714-336-0889	dnichols@TELACU.COM
10					
11					
12					